



# **MODEL 210**

## **RADIO COMMUNICATION SYSTEM**

### **INSTALLATION & OPERATION MANUAL**



---

# TABLE OF CONTENTS

---

<b>SYSTEM ORIENTATION</b> .....	1
About the 210 Intercom System .....	1
Items Included with the 210 Intercom .....	1
System Overview .....	2
210 Front & Rear Panels .....	3
Definitions .....	4
<b>PRE-INSTALLATION</b> .....	5
Intercom Location .....	5
Headset Modules .....	6
Daisy-Chaining the Headset Modules .....	7
Routing the CA Cables .....	8
Intercom Connections .....	8
Intercom Adjustments .....	9
Optional Foot Switch .....	9
<b>INSTALLATION</b> .....	10
Mounting the Intercom .....	10
Mounting the Headset Modules .....	10
Installing the CA Cables .....	11
Power & Ground Connections .....	12
Radio Connections .....	14
Intercom Adjustments .....	15
<b>SYSTEM TEST</b> .....	17
<b>OPERATION</b> .....	18
<b>MODULAR PLUG INSTALLATION</b> .....	22
<b>TROUBLESHOOTING</b> .....	23
<b>ADVANCED TROUBLESHOOTING</b> .....	26
<b>WIRING DIAGRAMS</b> .....	30
<b>OPTIONS &amp; ACCESSORIES</b> .....	32
<b>SPECIFICATIONS</b> .....	34
<b>WARRANTY</b> .....	35



---

# **SYSTEM ORIENTATION**

---

## **ABOUT THE 210 INTERCOM SYSTEM**

The Firecom Model 210 Apparatus Intercom System, when used with Firecom noise-attenuating headsets, provides protection from hearing loss that can occur from exposure to high noise levels, while also providing each firefighter clear communication with the other crew member.

Each crew member will hear all radio traffic and be able to communicate over the intercom. Crew members wearing Radio-Transmit Headsets may transmit over the apparatus radio from any headset station in the system.

The 210 Intercom features advanced circuitry that effectively suppresses distracting background noise and eliminates clipping without affecting communication. The result is clear, crisp on-board communication like never before.

## **ITEMS INCLUDED WITH THE 210 INTERCOM**

The following items are included with the Firecom Model 210 Intercom. Make sure you have all of these items **BEFORE** proceeding with the installation of the 210 Intercom.

- 1 - Model 210 Intercom unit
- 1 - Power Cable Assembly with In-Line Fuse Holder
- 1 - Installation and Operation Manual
- 1 - MR-0X Mobile Radio Interface Cable
- 4 - #6 X 1/2" Sheet Metal Screws

---

# SYSTEM ORIENTATION

---

## SYSTEM OVERVIEW

This section provides an overview of the 210 Intercom System and an introduction to its individual components. Figure 1 shows a typical system. Refer to this diagram for each component.

### INTERCOM

The main control unit for the 210 Intercom System.

### 2-WAY RADIO

The existing 2-way radio in the apparatus.

### MOBILE RADIO INTERFACE CABLE

Provides the interface connections between the 210 Intercom Unit and the 2-way radio in the apparatus.

### POWER CABLE ASSEMBLY

Provides the power connections for the 210 Intercom Unit. The power connections should be made at the same place as the power connections for your radio.

### HM-10 HEADSET MODULES

Headsets are plugged into the Headset Modules to interface them into the system. The HM-10 is the standard Headset Module for use inside the apparatus.

### PP-20 PUMP PANEL MODULE (not shown)

A water-resistant Headset Module for use on the exterior of the apparatus (i.e. at the pump panel, at the tail-board, etc.).

### CA CABLES

Six-conductor flat cable which connects the 210 Intercom Unit to the HM-10 and the PP-20 Headset Modules.

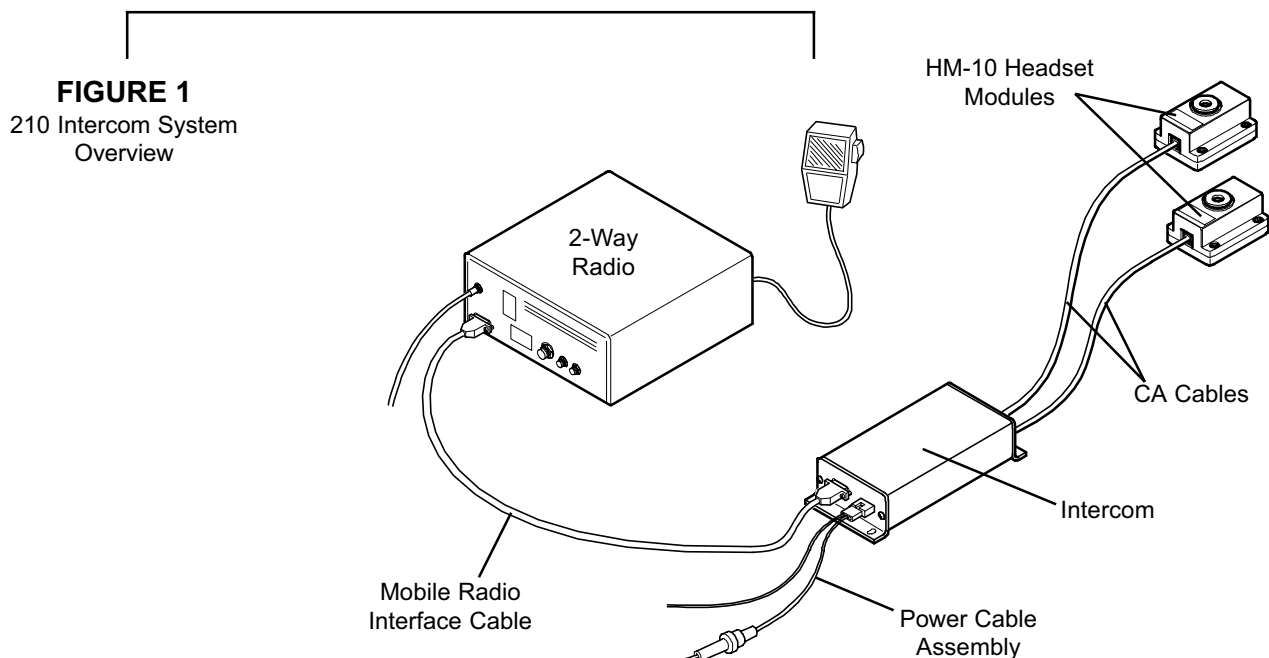

---

# SYSTEM ORIENTATION

---

## 210 FRONT & REAR PANELS

Figures 2 & 3 show the Front & Rear Panels of the 210 Intercom. Listed below are the different items found on the Front and Rear Panels, and their purpose.

### MODULAR JACKS

These modular jacks are the connection points for the CA Cables leading from the Intercom Unit to the Headset Modules.

### RADIO INTERFACE JACK

A 9-Pin D-Sub connector, which provides the attachment point for the Mobile Radio Interface Cable.

### POWER CONNECTOR

A 2-Pin connector, where the Power Cable Assembly is plugged in, interfacing the 210 Intercom to the vehicle's power supply.

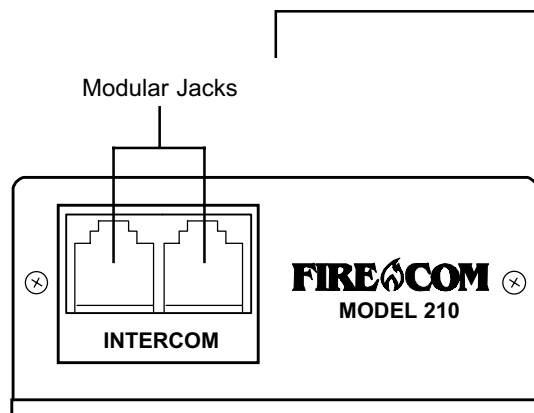

**FIGURE 2**  
210 Front Panel

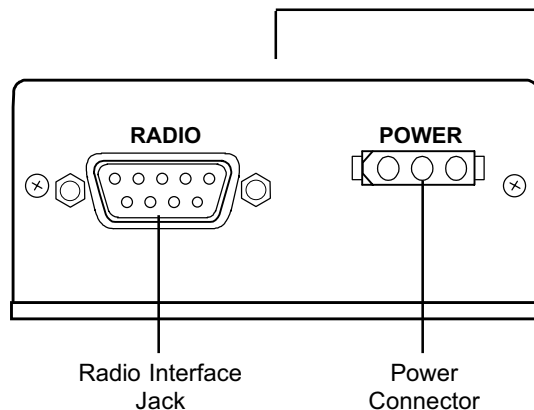

**FIGURE 3**  
210 Rear Panel

---

# SYSTEM ORIENTATION

---

## DEFINITIONS

This section lists some of the more common terms used in this manual and gives their description. Familiarize yourself with these terms before proceeding with the installation of a 210 Intercom.

- CA Cable:** Flat, six conductor cable, which may have RJ-12 Modular Plugs on each end, used to make connections between the intercom unit and the HM-10's or PP-20's.
- Headset Location:** Any combination of CA Cables, HM-10's, PP-20's and headsets connected to a single port on the front of the intercom unit.
- HM-10:** Black plastic module with a single headset jack used to connect a headset into the intercom system. For use inside the vehicle.
- Intercom Audio:** Audio present when communicating via the intercom system. Intercom audio is heard only on board the apparatus.
- Intercom-Only Headset:** The Intercom-Only Headset receives both intercom and receive audio at all times. This headset has a **Black** or **Yellow** PTT for intercom communication, and is **NOT** capable of radio transmission.
- Intercom Port:** Any one of the 2 modular jacks on the front of the Intercom Unit.
- PP-20:** A round metal, water resistant, module with a single jack for headset connection. For use on the exterior of the vehicle.
- Radio Interface Port:** A 9-pin D-sub jack on the rear of the Intercom Unit.
- Radio Interface Cable:** The cable which plugs into the Radio Interface Port on one end, and connects to a 2-way radio on the other.
- Radio-Transmit Headset:** The Radio-Transmit Headset receives both intercom and receive audio at all times. The mic is always active for intercom communication, and has a **Red** PTT for radio communication.
- Receive Audio:** Audio from incoming radio transmissions. This is the same audio that is heard from the radio's speaker.
- RJ-12 Modular Plug:** The six conductor plugs on the ends of the CA Cables. These connectors plug into the Headset Modules and the Intercom Unit.
- Transmit Audio:** Audio signals being transmitted on the radio via a Radio-Transmit Headset with the **Red** PTT button pressed.

---

# PRE-INSTALLATION

Before installing the Firecom Model 210 Intercom System, it is **VERY IMPORTANT** to take a little time and plan the installation. This section will provide information to assist in planning the installation. You should read **AND UNDERSTAND** all of the information contained in this section, as well as the sections on the *System Orientation* (page 1) and *Installation* (page 10) **BEFORE** installing the 210 onto the apparatus.

**Taking a little time to plan the installation BEFORE installing the 210 Intercom System may prevent many installation errors which could result in improper system operation.**

**IMPORTANT**

If you have any questions regarding the information contained in this section, contact your local Firecom Dealer for clarification **BEFORE** proceeding with the installation.

## INTERCOM LOCATION

When choosing a location to mount the 210 Intercom Unit, the following conditions should be considered:

- The intercom should be close to the 2-way radio and the appropriate power connections.
- Allow for at least 3 inches clearance on the sides and rear of the intercom unit for service and installation.
- The intercom should be placed where it will be easy to route the CA Cables from the Headset Modules.

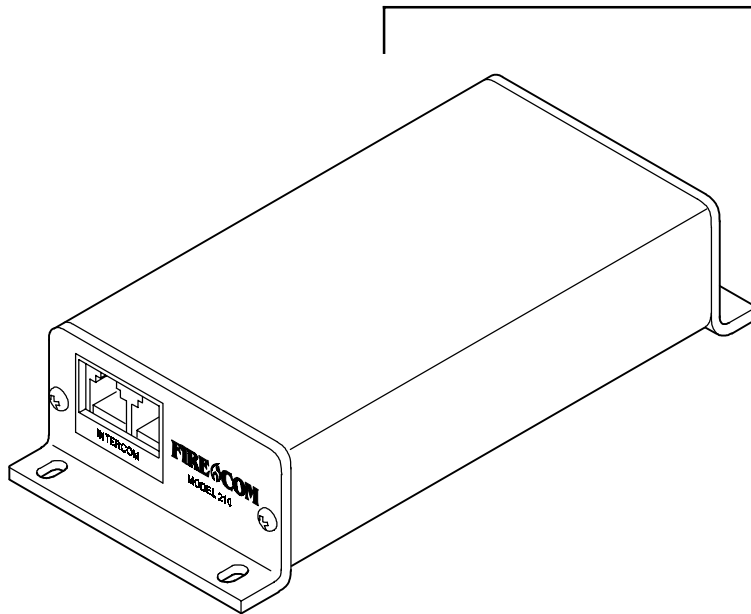

**FIGURE 4**  
Model 210 Intercom

---

# PRE-INSTALLATION

## HEADSET MODULES

There are 2 different types of Headset Modules for the 210 Intercom system. The HM-10 (Figure 5) is the standard module and is designed for use inside the apparatus where it is protected from the elements. The HM-10 also has a second connection for Daisy-Chaining (page 7).

The second type of headset module is the PP-20 (Figure 6). The PP-20 is a water and corrosion resistant module for use on the exterior of the apparatus (i.e. the pump panel, the tail-board, etc.).

### IMPORTANT

**Even though this manual talks about the HM-10 and the PP-20 (along with the associated headsets), it is also possible to use the HM-3 (Figure 7) and the PP-3 with the 210 system. All installation and operation procedures with the HM-3 and PP-3 are the same as those outlined in this manual.**

Listed below are some of the items to consider when choosing the location of the headset modules:

- The module should be placed convenient to the user.
- The module should be placed with the plug facing the direction of exit from the vehicle. This may help to prevent damage to the headset plug, comm cable or the headset module itself if the user attempts to exit the vehicle while still wearing the headset.
- The headset comm cable should hang clear of obstructions.
- The modules should be mounted close enough to the windows so the user may look out the window without straining the headset module or the comm cable.
- The modules should be positioned so that routing the CA Cables to the modules can be accomplished in a neat and orderly fashion.
- The modules should be placed to provide access to the jacks on the module for the CA Cables. The CA Cable from the intercom will be inserted into the jack beneath the label on the headset module.
- If you are connecting two headset modules via a “Daisy-Chain”, allow clearance on the side opposite the label on the HM-10 for the CA Cable to be routed to the second headset module (see “Daisy-Chaining the Headset Modules” on page 7).

**FIGURE 5**

HM-10 Headset Module

**FIGURE 6**

PP-3 and PP-20 Headset Modules

**FIGURE 7**

HM-3 Headset Module

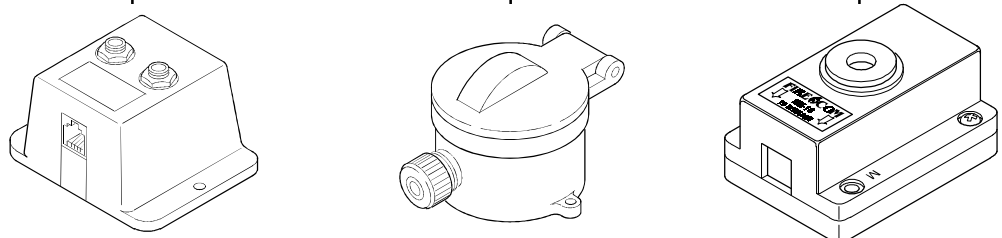

---

# PRE-INSTALLATION

## DAISY-CHAINING THE HEADSET MODULES

Daisy-Chaining the Headset Modules is a method used to increase the number of headset positions available, or a method of reducing the number of cable runs and the length of the cable runs. Daisy-Chaining the Headset Modules is easy to accomplish, but must be well thought out in advance considering the following requirements:

- The Headset Modules in a Daisy-Chain must be connected in a **SPECIFIC** manner (Figure 8).
  - The CA Cable from the Intercom unit should **ALWAYS** be plugged into the Headset Module via the modular jack under the label.
  - The modular jack on the other end of the Headset Module (behind a removable plastic tab), is for the CA Cable which leads to the next Headset Module in the Daisy-Chain.
- **DO NOT** mix headset types (Intercom-Only vs. Radio-Transmit) that are plugged into a Daisy-Chain.
- A **maximum** of 2 Intercom-Only Headsets may be plugged into a Daisy-Chain at any time.
  - You may have more Headset Modules in the Daisy-Chain, but **NEVER** plug more than 2 Intercom-Only Headsets into the Daisy-Chain at any one time.
- A **maximum** of 1 Radio-Transmit Headset may be plugged into a Daisy-Chain at any time.
  - You may have more Headset Modules in the Daisy-Chain, but **NEVER** plug more than 1 Radio-Transmit Headset into the Daisy-Chain at any one time.

**Improper Daisy-Chains in a system may result in operational problems and reduced system performance. If you have any questions regarding Daisy-Chains, contact your local Firecom Dealer for more information.**

**IMPORTANT**

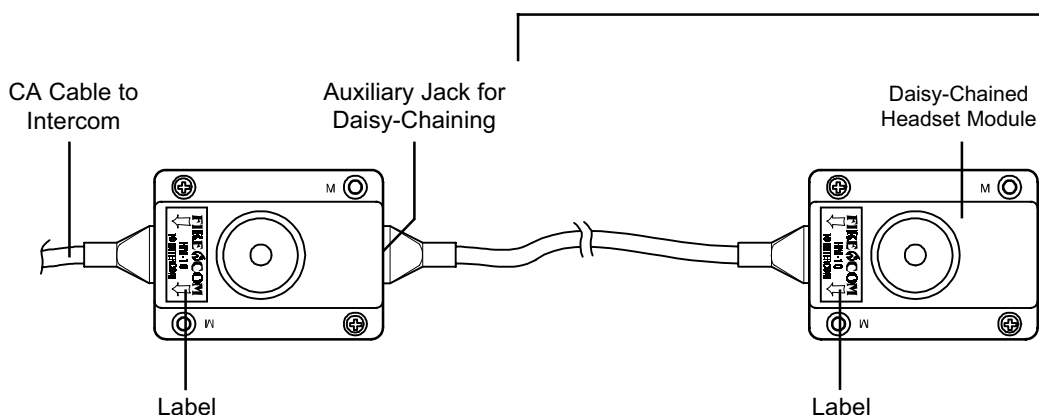

**FIGURE 8**  
Daisy-Chaining the Headset Modules

---

# PRE-INSTALLATION

## ROUTING THE CA CABLES

**BEFORE** installation, plan a path to run the CA Cables from the Intercom to the Headset Modules. Here are the important considerations:

- Route the CA Cables away from hot surfaces (such as the vehicle exhaust system).
- Route the CA Cables away from any moving equipment on the vehicle.
- Route the CA Cables away from the antenna or the antenna cable.
- **DO NOT** store excess cable. The length of each CA Cable should allow for approximately 10 inches of excess cable in each run for service loops (**VERY** important, especially in installations with a high-power radio operating in the lower frequencies).
- When routing the CA Cables through bulkheads or other sheet metal, use a rubber grommet in the hole to prevent damage to the cables.

## INTERCOM CONNECTIONS

### MODULAR JACKS

On the front of the intercom, there are 2 modular jacks (Figure 9). These jacks are for connecting the CA Cables from the Headset Modules to the intercom. Both of these modular jacks will provide intercom and radio communication to the headset positions.

### POWER CONNECTIONS

The 210 Intercom requires +12 volts DC (with a negative ground) at 0.50 amps. The 210 Intercom comes with a Power Cable Assembly and a 1/2 amp, fast blow, in-line fuse. We suggest connecting the Intercom power and ground to the apparatus power busses, preferably to the same connection points as the radio.

### RADIO INTERFACE

A universal Radio Interface Cable is supplied with the 210 Intercoms. This cable is a 9-wire, shielded cable which terminates with bare wires.

**IMPORTANT**

**ALL connections to the 2-way radio should be performed by a Qualified Radio Technician to ensure proper interface between the 2-way radio and the 210 Intercom System.**

There are many different interface cables available from Firecom to interface the 210 Intercom with specific radios. These “dedicated” interface cables will make interfacing the radio easier, but should still be done by a qualified radio technician. Contact your local Firecom Dealer for more information regarding the availability of an interface cable for your radio.

# PRE-INSTALLATION

## INTERCOM ADJUSTMENTS

After the Intercom System and the radio interface have been properly installed, there are some adjustments which **MUST** be performed for proper operation of the system. The Intercom Adjustments are outlined on page 15 in this manual.

**These adjustments to the intercom MUST be performed by a qualified Radio Technician to ensure proper operation of the 2-way radio and 210 Intercom System.**

**IMPORTANT**

## OPTIONAL FOOT SWITCH

The optional Foot Switch (FS-1) is used in situations where the user cannot, or does not wish to, use the headset mounted Push-To-Talk. The Foot Switch is plugged into the Daisy-Chain Jack (Figure 11) on the Headset Module of the person using the Foot Switch. When selecting the location of the Foot Switch, it should be convenient to the user, but in a location where it will not be accidentally depressed. Routing the CA Cable to that headset module must also be considered when choosing a location.

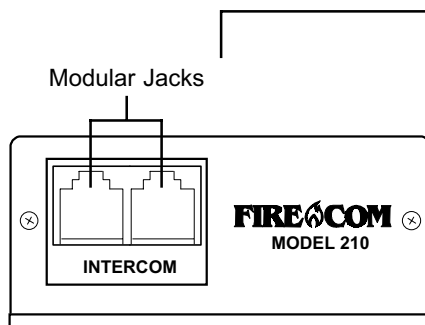

**FIGURE 9**  
210 Front Panel

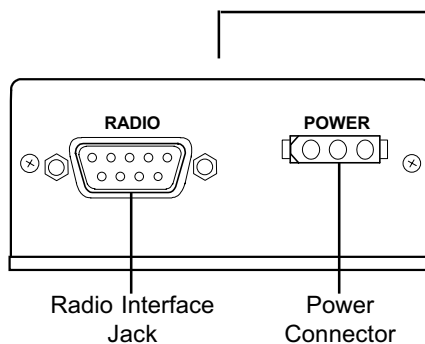

**FIGURE 10**  
210 Rear Panel

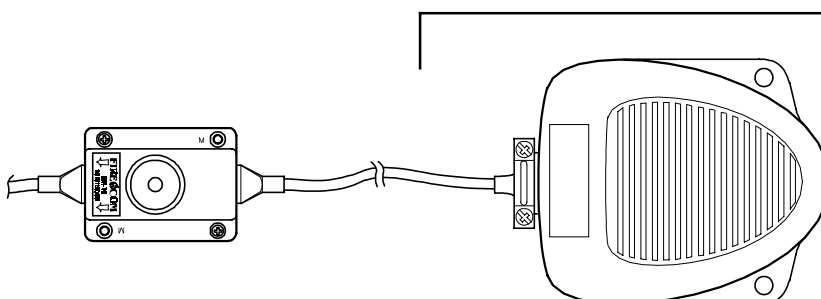

**FIGURE 11**  
Foot Switch (Remote PTT)

# INSTALLATION

## IMPORTANT

**BEFORE** installing the Firecom 210 Intercom System, make sure you have read **AND** have **UNDERSTOOD** the **ENTIRE** installation procedure. You should also read the sections on Pre-Installation (page 5) and System Orientation (page 1). If any item in the Installation Procedure is not understood, or if you have any questions which are not addressed in this manual, contact you local Firecom Dealer for more information **BEFORE** you proceed with the installation.

## MOUNTING THE INTERCOM

1. Using the 210 Intercom as a template, mark the location of the mounting holes (Figure 12).
2. Drill 4 holes for the #8 sheet metal screws (supplied).

## IMPORTANT

**Before drilling, be sure to check the area behind the panel holes to ensure that it is free of wires or other obstructions that could be damaged.**

3. Install the Intercom Unit with the sheet metal screws.

**FIGURE 12**  
Mounting the 210  
Intercom

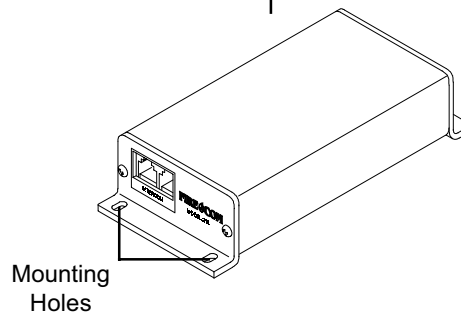

## MOUNTING THE HEADSET MODULES

4. Using the Headset Module as a template (Figure 13), mark the location of the mounting holes. The holes in the HM-10 used for mounting the module are marked with a letter "M".
5. Drill 2 holes for the #6 sheet metal screws (supplied).

## IMPORTANT

**Before drilling, be sure to check the area behind the panel holes to ensure that it is free of wires or other obstructions that could be damaged.**

6. Position the Headset Module and secure with the provided sheet metal screws.

**FIGURE 13**  
The Headset Modules

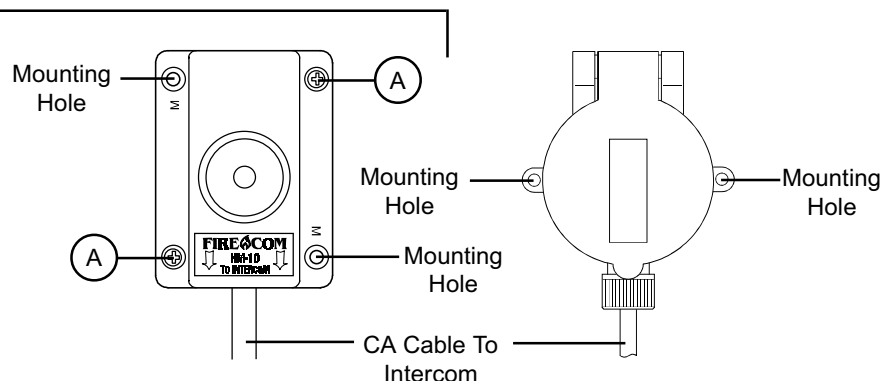

# INSTALLATION

## INSTALLING THE CA CABLES

- Slide a Bend Relief Grommet over one end of the flat CA Cable, (small end first).
- Attach a RJ-12 Modular Plug to the end of the flat CA Cable (see “Modular Plug Installation” on page 22 for instructions if necessary).

**ALWAYS make sure the printed side of the cable is facing the release-tab on the RJ-12 Modular Plug (Figure 14). This ensures proper orientation of the plug on each end of the cable.**

IMPORTANT

- Remove the screws labeled "A" in Figure 13 holding the HM-10 together and remove the bottom plate of the HM-10.
- Lift the jack slightly out of the HM-10 and insert the RJ-12 Modular Plug into the Jack in the HM-10 as shown in Figure 15.

**If the CA Cable is going from the Headset Module to the Intercom, it MUST be inserted into the Modular Jack on the same side of the HM-10 as the “Fire-com” label. If the CA Cable is part of a “daisy-chain”, you will need to remove the plastic tab which covers the access hole to the second Modular Jack on the HM-10. See “Daisy-Chaining the Headset Modules” (page 7).**

IMPORTANT

- Insert the Bend Relief Grommet into the HM-10 so the groove in the grommet is over the side case of the HM-10 (Figure 15).
- Replace the bottom plate of the HM-10 and secure with the 2 screws.
- Mount the HM-10 in place on the apparatus.
- Route the CA Cables to the front of the Intercom Unit (or the next Headset Module in a Daisy-Chain).
- Attach an RJ-12 Modular Plug to the other end of the flat CA Cable (see “Modular Plug Installation” on page 22 for instructions if necessary).
- With the “release-tab” on the RJ-12 Modular Plug facing up, insert the RJ-12 Modular Plug into a modular jack on the front of the intercom unit.
- Repeat steps 7 through 16 until all remaining Headset Modules have been connected with the CA Cable to the Intercom Unit or the next Headset Module in a Daisy-Chain.

**FIGURE 14**  
The RJ-12 Modular Plug

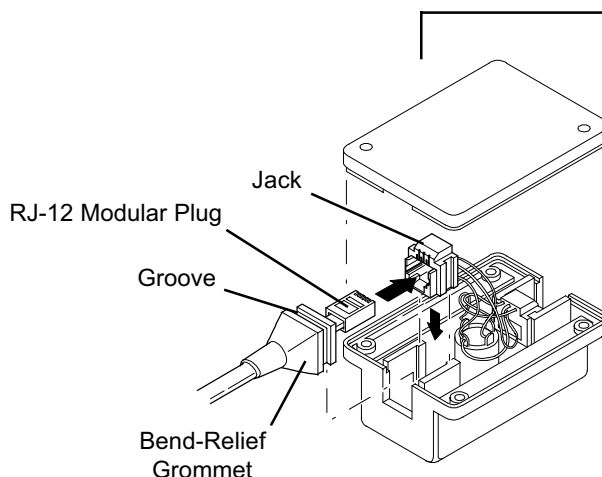
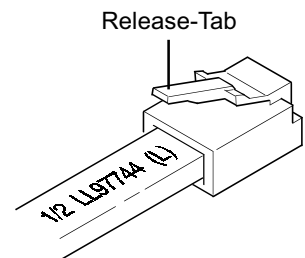

**FIGURE 15**  
Installing a CA Cable into  
a HM-10 Module

# INSTALLATION

## POWER & GROUND CONNECTIONS

- IMPORTANT** Before making the power connections, make sure the apparatus master switch is OFF!
18. Connect the Power Cable Assembly to the rear of the Intercom Unit.

**FIGURE 16**  
210 Rear Panel

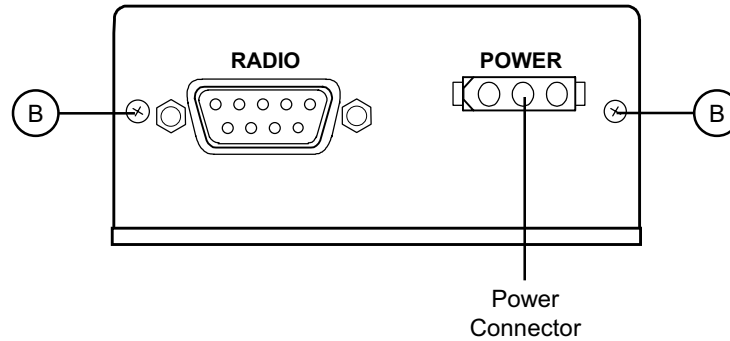

19. Connect the black wire (from pin 1) to the vehicles negative ground.
- IMPORTANT** We suggest connecting the intercom power connections to the apparatus power busses (preferably, to the same point that the 2-way radio is connected).
20. Connect the red wire (from pin 2) to the vehicles switched +12 VDC.
21. Remove the 4 screws mounting the 210 Intercom in place.

**FIGURE 17**  
Power Cable Assembly

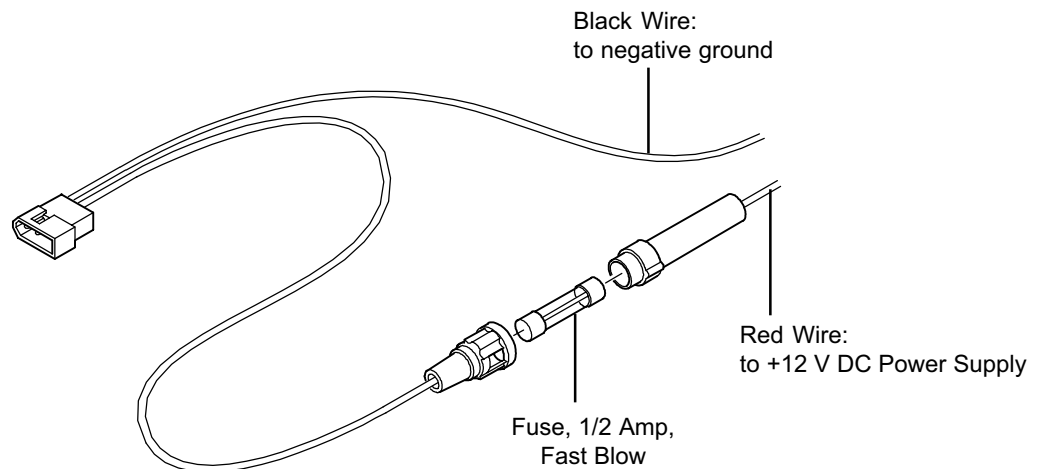

# INSTALLATION

22. Remove the 2 screws on the rear panel of the intercom (labeled "B" in Figure 16).
23. Slide the Rear Panel and the Circuit Board partially out of the rear of the intercom (Figure 18).

**DO NOT completely remove the circuit board from the intercom box. If the board is removed and set down on a flat surface, it may be possible for something to contact the back of the board and cause a short circuit, damaging the board.**

**IMPORTANT**

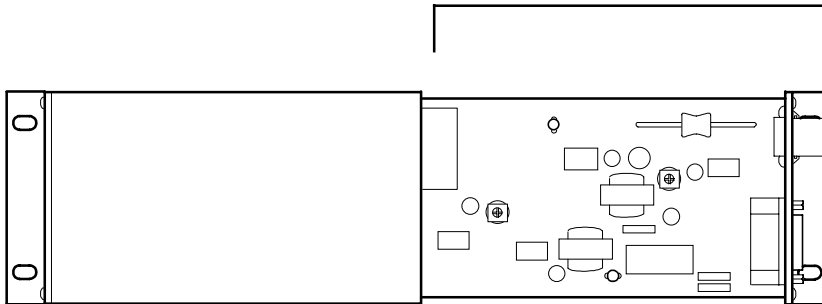

**FIGURE 18**  
Keep the front of the board  
in the case

24. Plug the Power Cable into the back of the 210.
25. Apply power to the Intercom Unit. The Red LED (D1 in Figure 19) should light.
26. Press the Red Push-To-Talk (PTT) Button on one of the Radio-Transmit Headsets. The Yellow LED (D7 in Figure 19) should light, and then go out when the PTT is released.
27. Slide the Circuit Board back into the intercom case.

The 210 Intercom System is installed and ready for connection to the radio.

**If you are not interfacing the 210 to the radio now, you should re-install the 2 screws on the rear of the intercom**

**IMPORTANT**

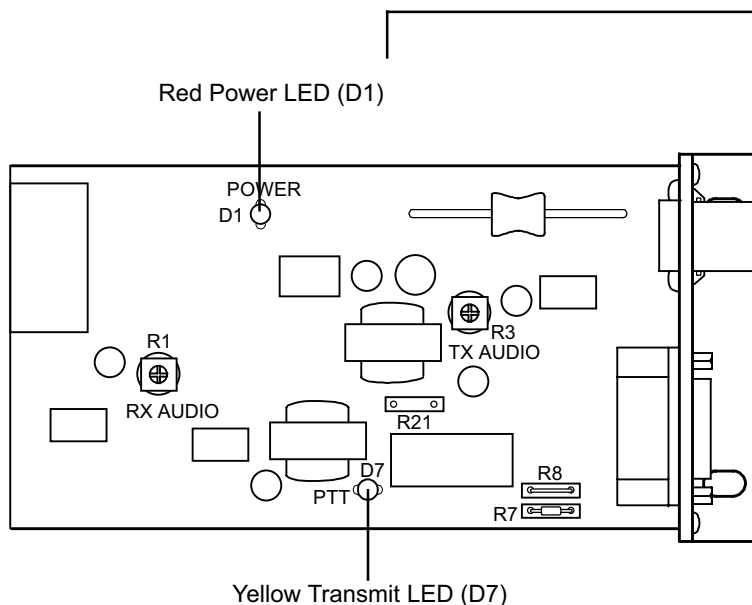

**FIGURE 19**  
210 Circuit Board

# INSTALLATION

## RADIO CONNECTIONS

### IMPORTANT

To ensure proper operation, the connection to the radio should be performed by a qualified Radio Technician.

### IMPORTANT

If you are unsure if your Interface Cable is the proper one, or if you want to know if Firecom manufactures a Radio-Specific Interface Cable for your radio(s), contact your local Firecom Dealer.

### IMPORTANT

28. If you are using a radio-specific interface cable, follow the directions included with the interface cable, then proceed with step 31 (page 15) in this Installation Procedure.
29. Plug the 9-Pin plug on the end of the supplied MR-0X Mobile Radio Interface Cable into the Radio Interface Jack on the rear of the intercom (Figure 20).
- Tighten the 2 screws on the plug of the MR-0X. If these screws are not tightened, the 9-pin plug may vibrate loose and cause problems with transmission, reception or other radio problems.**
30. Using the information in Figure 21, connect the wires on the MR-0X Mobile Radio Interface Cable to the appropriate places on the 2-way radio.

**FIGURE 20**

210 Rear Panel

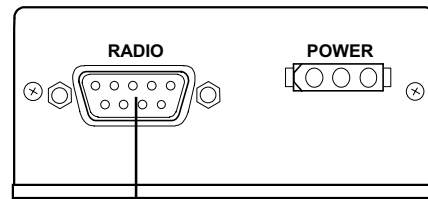

Radio Interface Jack

**FIGURE 21**

MR-0X Universal Radio Interface Cable

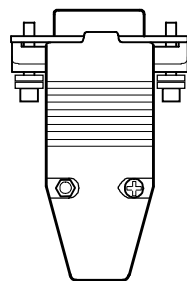

9-Pin Plug:  
to Intercom  
Radio  
Interface Port

- Pin #1: Brown - TX Audio Hi
- Pin #2: Red - TX Audio Lo
- Pin #3: Orange - PTT Hi
- Pin #4: Yellow - PTT Reference
- Pin #5: Green - No Connection
- Pin #6: Blue - RX Audio Hi
- Pin #7: Violet - RX Audio Lo
- Pin #8: Gray -No Connection
- Pin #9: Black - No Connection

# INSTALLATION

## INTERCOM ADJUSTMENTS

In order to match the Transmit and Receive Audio to the radio, it will be necessary to perform some adjustments inside the Intercom Unit. These items are adjusted by variable resistors located on the circuit board inside the intercom unit (Figure 23).

**These adjustments MUST be performed by a Qualified Radio Technician. Failure to perform these adjustments may result in problems hearing and transmitting radio signals when using the Intercom System.**

IMPORTANT

### RECEIVE AUDIO ADJUSTMENT:

31. Turn the 2-way radio on, and adjust the radio volume to the normal volume level for use **WITHOUT THE INTERCOM INSTALLED.**
32. Slide the Rear Panel and the Circuit Board partially out of the rear of the intercom (Figure 22).

**DO NOT completely remove the circuit board from the intercom box. If the board is removed and set down on a flat surface, it may be possible for something to contact the back of the board and cause a short circuit, damaging the board.**

IMPORTANT

33. Adjust R1 (Figure 23) to set the Receive Audio so that it is at the same level as the audio heard when listening to someone speak over the intercom.

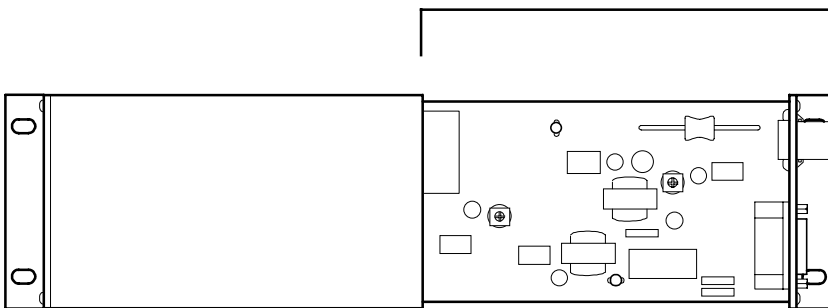

**FIGURE 22**  
Keep the front of the board  
in the case

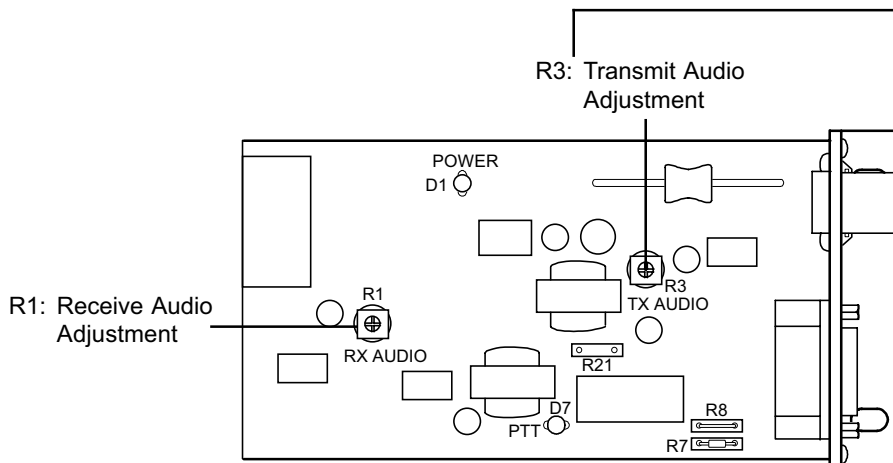

**FIGURE 23**  
210 Circuit Board

# INSTALLATION

## TRANSMIT AUDIO ADJUSTMENT:

- Using a Service Monitor, adjust Variable Resistor R3 (Figure 24) for proper transmitter deviation and no transmitted audio clipping.

### IMPORTANT

If it is necessary to adjust R3 to its minimum setting, cut the jumper labeled R8 (Figure 24) and re-adjust R3.

The Transmit Audio Circuit is coupled to the radio and provides no DC path between Transmit Audio High and Transmit Audio Low. For radios that require a resistive load on the mic input install a suitable value resistor on the board in the location marked R21 (Figure 24). When the 210 keys the radio, R21 will be in parallel with the mic circuit.

### IMPORTANT

Resistor R21 should be added ONLY if it is necessary and should be performed ONLY by a Qualified Radio Technician.

- Slide the Circuit Board back into the 210 case.
- Re-install the 2 screws labeled "C" in Figure 25 on the rear panel of the Intercom Unit.
- Mount the Intercom Unit back in place.

**FIGURE 24**  
Jumper and Resistor Positions

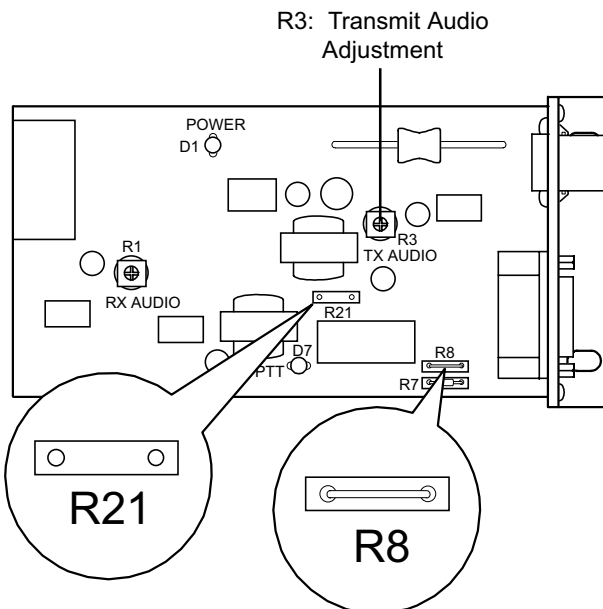

**FIGURE 25**  
210 Rear Panel

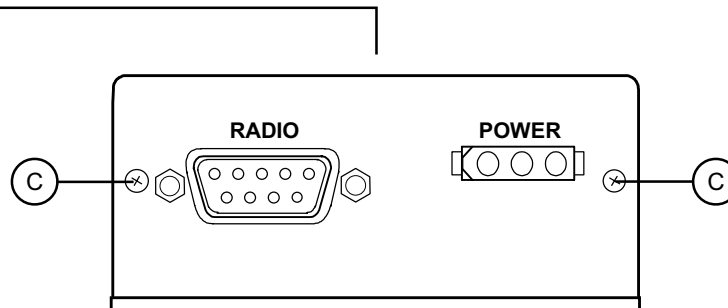

---

## **SYSTEM TEST**

---

This procedure tests all functions of the 210 Intercom System and should be used to test the system for proper operation after installation. In the event of a system failure, it may also be used to help identify and isolate the exact symptoms before troubleshooting a problem, and to test the system after repair work has been performed.

1. Turn on the apparatus master switch.
2. Turn on the radio (if it is not already on).
3. Plug a headset into the appropriate Headset Module.
4. Put a headset on your head and adjust the headband/headstrap for a comfortable fit (see “Headset Adjustment” on page 20).
5. Adjust the microphone boom to place the microphone in front of your mouth and approximately 1/8” from your lips (see “Microphone Placement” on page 21).
6. Check the Intercom operation.
  - If the headset is a UH-10 or FH-10, speak into the microphone to confirm intercom operation. You should hear yourself through the headset speakers.
  - If the headset is a UH-20 or FH-20, press and hold the black Push-To-Talk (PTT) button on the ear dome while speaking into the microphone.
  - If the headset is a UH-40 or FH-40, you may need to press, and release, the yellow PTT button on the ear dome to turn the microphone on before speaking into the headset.
7. While speaking into the microphone, adjust the volume control on the headset for a comfortable listening level.
8. Monitor radio communications. Verify that the incoming radio transmissions are the same volume as the intercom volume.
9. Repeat steps 4 to 8 for each headset position on the apparatus.

**Steps 10 to 12 are for Radio-Transmit Headsets only! These are the models FH-10, FH-10S, UH-10 and UH-10S, and have a red PTT on the ear dome.**

**IMPORTANT**

10. Put on a Radio-Transmit Headset (Model FH-10, FH-10S, UH-10 or UH-10S).
11. Test radio transmission by pressing the red PTT button on the ear dome and speaking into the microphone. You should transmit on the radio.
12. If there is an optional foot switch installed, test radio transmission by pressing the foot switch and speaking into the microphone on the headset.
13. Repeat steps 10 to 12 for each Radio-Transmit Headset on the apparatus.

Final adjustment of the volume controls may be required under actual apparatus operating conditions.

---

# OPERATION

## INTERCOM

### RADIO VOLUME

The volume of the radio heard in the headsets is primarily controlled by the radio's volume control, and secondarily by the Receive Audio Adjustment inside the 210 Intercom.

- The radio should be set at the volume normally used when an intercom is NOT installed.
- The Receive Audio Adjustment in the intercom should be adjusted following the procedure on page 15 of this manual.

### INTERCOM VOLUME

The volume of intercom communication heard in the headsets is controlled by the following 3 items:

1. **Headset Volume Control:** Each headset has a volume control located on the Ear Dome. This is a master volume control for the headset.
2. **Microphone Placement:** Placement of the microphone is CRITICAL for proper operation. See the section on “Microphone Placement“ on Page 21.
3. **Speaking Volume:** The volume you speak will affect how loud the intercom communication is heard.

## HEADSETS

Firecom offers many different styles of headsets for use with the 210 Intercom System. Headsets are available in an Over-The-Head (Figure 26), or Under-The-Helmet (Figure 27) style. Either of these styles can be Radio-Transmit capable, or Intercom-Only.

For more information regarding the different models of headsets available, contact your local Firecom Dealer.

**FIGURE 26**  
FH Style Headset

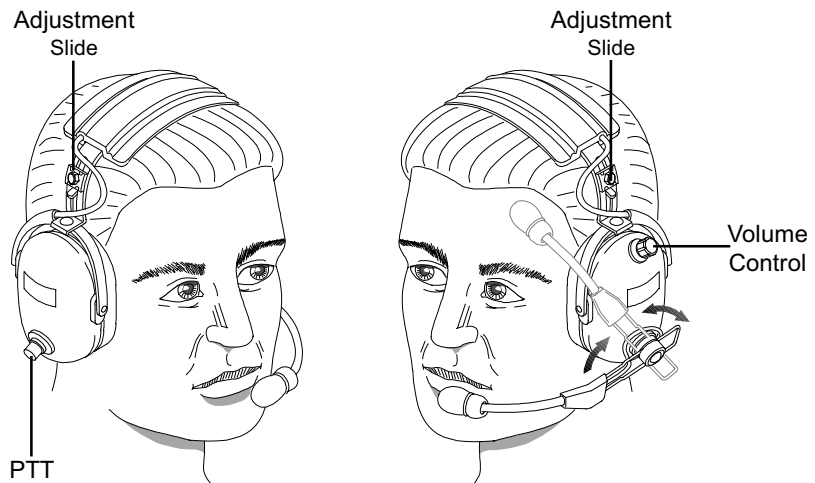

---

# OPERATION

---

## RADIO-TRANSMIT HEADSETS

The Radio-Transmit Headsets receive both intercom and radio communications at all times. The mic is always activate for intercom communications. Radio-Transmit Headsets are typically used at the Driver, Officer and Pump Panel positions.

There are 2 models of Radio-Transmit Headsets available for use with the 3010 Series Intercom System: the UH-10 and the FH-10. There is a RED Push-To-Talk (PTT) button located on the ear dome which allows communication on the radio.

## INTERCOM-ONLY HEADSETS

The Intercom-Only Headsets receive both intercom and radio communications at all times, but are NOT radio-transmit capable. Intercom-Only Headsets are typically used at the jumpseat positions, due to the high ambient noise level at these locations (engine noise, etc.).

There are 4 models of Intercom-Only Headsets: the UH-20, the FH-20, the UH-40 and the FH-40.

- The UH-20 and the FH-20 have a BLACK PTT button on the ear dome. Press and hold this black PTT to speak on the intercom.
- The UH-40 and the FH-40 have a YELLOW PTT on the ear dome. Press and release the yellow PTT to turn the microphone on. Press and release the yellow PTT again to turn the microphone off.

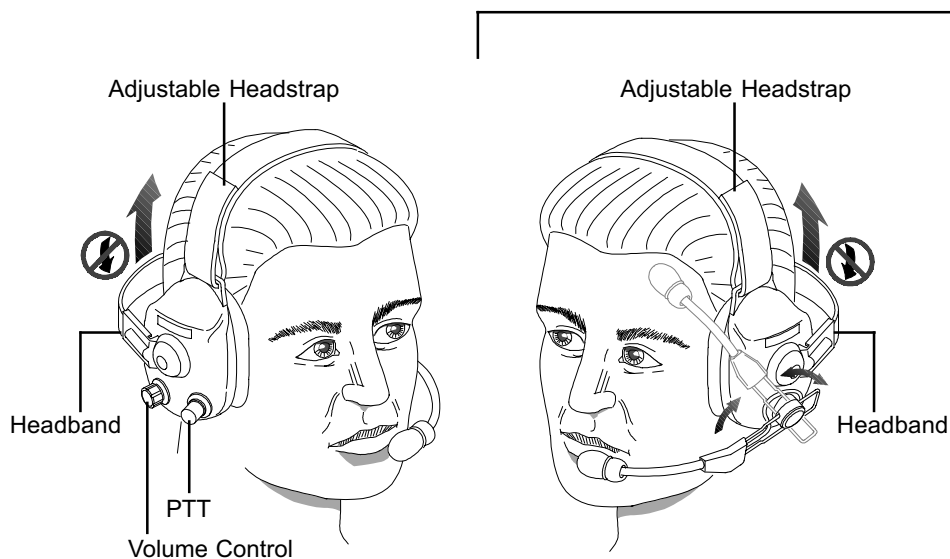

**FIGURE 27**  
UH Style Headset

---

# OPERATION

## HEADSET ADJUSTMENT

The vertical fit of the headset is changed by adjusting the headband (FH models) or the headstrap (UH models).

- Over-The-Head (FH) style headsets (Figure 28): These headsets have adjustable headbands with slide mechanisms located at each side above the ear domes. If the adjustment slides become loose, gently tighten the self-locking nuts on the slide mechanisms.
- Under-The-Helmet (UH) style headsets (Figure 29): These headsets have an adjustable headstrap to adjust the height of the ear domes.

For maximum comfort, wear the headset as far back on the head as possible, while ensuring that the ear domes still completely cover the ears. If discomfort is felt in the jawbone, you are wearing the headset too far forward.

**FIGURE 28**  
FH Style Headset

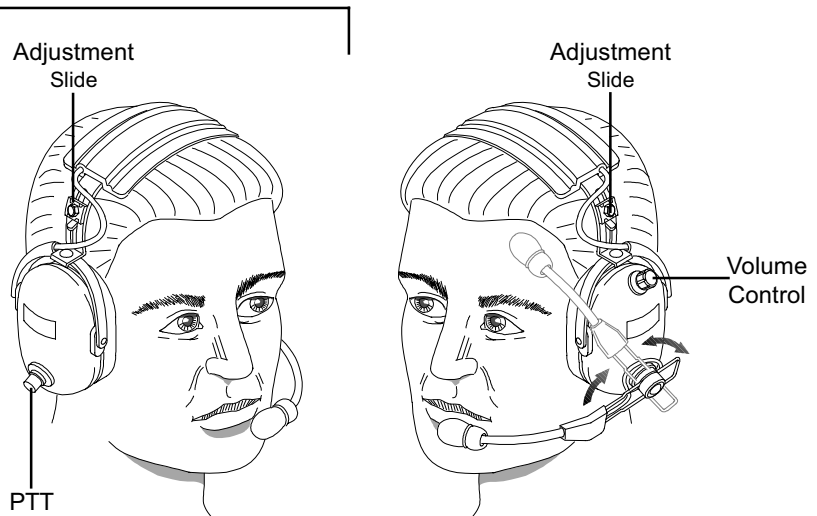

**FIGURE 29**  
UH Style Headset

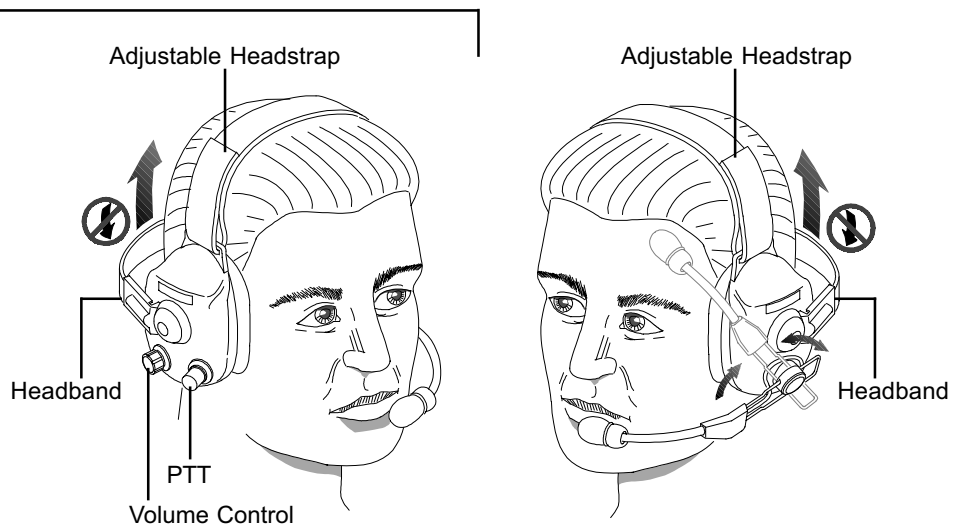

---

# OPERATION

## MICROPHONE PLACEMENT

The microphones used on Firecom headsets are noise-canceling electret microphones. The placement of the microphone is **VERY** important. For proper operation, the microphone should be positioned in front of the mouth and no more than 1/8" away from the lips (Figure 30).

**Placement of the microphone is CRITICAL. If the microphone is positioned incorrectly, you will experience drastic reduction in volume and clarity of the intercom and radio communication.**

**IMPORTANT**

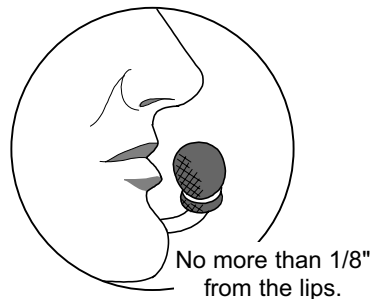

**FIGURE 30**  
Microphone Placement

## LEFT & RIGHT DRESS

The Firecom headsets may be adjusted so that the mic is on the right side (right dress) or left side (left dress).

- Over-The-Head (FH) style headsets: Rotate the Mic Boom **ONLY** in an upward direction (Figure 28).

**ALWAYS rotate the Mic boom upwards as shown to prevent damage to the Mic Boom and the Mic Cable.**

**IMPORTANT**

- Under-The-Helmet (UH) style headsets: Rotate the Mic Boom and the rear Headband **ONLY** in an upward direction (Figure 29).

**ALWAYS rotate the Mic Boom and the rear Headband upwards as shown to prevent damage to the Mic Boom, the Mic Cable and the Headband Cable.**

**IMPORTANT**

## HEADSET VOLUME CONTROL

Located on the ear dome of each Firecom Headset is a volume control for adjusting the volume of headset speakers. This allows each user to adjust the volume to the preferred level. Turning the volume control clockwise increases the volume, turning the control counterclockwise decreases the volume.

# MODULAR PLUG INSTALLATION

This section describes the installation of the RJ-12 Modular Plugs onto the flat CA Cable.

1. Using the cutter blade on the crimping tool (labeled “A” in Figure 31), cut the flat CA Cable so the cut is clean and 90 degrees to the sides of the cable.

**FIGURE 31**  
RJ-12 Modular Plug  
Crimping Tool

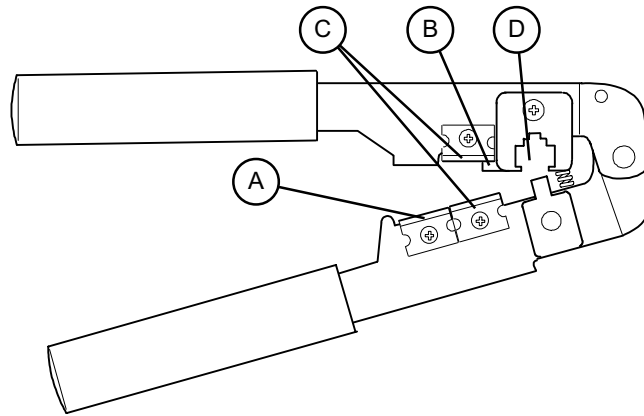

**FIGURE 32**  
The Stripped CA Cable

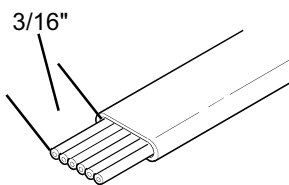

2. Fully insert one end of the CA Cable between the stripping blades (labeled “C” in Figure 31) until the end of the cable hits the stop (labeled “B” in Figure 31).
3. Squeeze the handles of the crimping tool together until the tool bottoms out.
4. While holding the handles together, pull the cable out of the tool.
5. The stripped insulation should expose approximately 3/16” of wire (Figure 32).
6. Push a RJ-12 Modular Plug into the plug holder on the crimping tool (labeled “D” in Figure 31) until the release tab on the plug locks into position.
7. Holding the cable so that the printed side of the cable is toward the release-tab on the plug, push the cable into the plug as far as it will go.

## IMPORTANT

**ALWAYS make sure the printed side of the cable is facing the release-tab on the RJ-12 Modular Plug (Figure 33). This ensures proper orientation of the plug on each end of the cable.**

**FIGURE 33**  
The RJ-12 Modular Plug

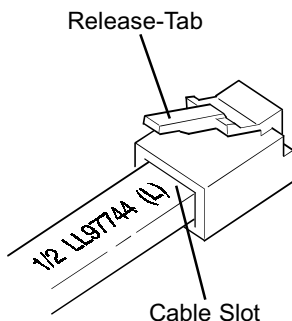

8. Squeeze the tool handles **COMPLETELY** together. You may feel the crimper finish punching the contacts through the insulation on the wires.
9. Let the handles spring open.
10. Push down on the release-tab on the RJ-12 Modular Plug (Figure 33) and remove the RJ-12 Modular Plug from the crimping tool.
11. Inspect the plug to ensure that the cable is held securely in place.
12. Repeat this procedure as necessary to install a RJ-12 Modular Plug on each end of each CA Cable.

---

## **TROUBLESHOOTING**

The Firecom 210 Intercom System, when installed properly, and adjusted according to specifications, will perform reliably and offer you the finest in hearing protection and enhanced communication. However, as with any electronic equipment, occasionally a malfunction may occur.

In the following sections, you will find information that will help familiarize you with the intercom system and aid in the troubleshooting process.

If the symptoms you are experiencing are not covered in this manual, or if you are having difficulty troubleshooting your system, contact your local Firecom Dealer for assistance.

### **IF THE SYSTEM DOES NOT OPERATE AS EXPECTED, CHECK THE FOLLOWING ITEMS FIRST**

- √ Check that the apparatus master switch is on.
- √ Check the fuse or circuit breaker.
- √ Check system wiring and interconnections.
- √ Check the orientation of **ALL** RJ-12 Modular Connectors on **BOTH** ends of each CA Cable. See “Modular Plug Installation” (page 22).
- √ Check that the headsets are plugged in all the way.
- √ Check intercom and headset control settings.
- √ Check for corrosion on headset plugs.
- √ Check all intercom ports for bent or stuck pins that can be straightened.

If these steps do not correct the problem, continue with the Advanced Troubleshooting procedures on page 26.

---

# **TROUBLESHOOTING**

## **ALTERNATOR WHINE & OTHER DISTRACTING NOISES**

Because of the level of ambient noise present with the apparatus motor running, alternator whine and other noises may not be noticed in the communications systems until an intercom is added. A noisy system will always be apparent, however, once an intercom is installed.

### **Common Causes of Noise on the Communication Circuit**

- Improper installation
- Intercom adjusted improperly
- Radio Interface not connected properly
- Intercom power connections dirty, loose or connected to the wrong location
- Battery terminals corroded
- A faulty alternator

Generally, the problem is not caused by the alternator. It is usually the result of a difference in potential between the apparatus radio signal ground and the intercom signal ground. Additional sources may also exist in the apparatus electrical system.

### **To Reduce or Eliminate Alternator Whine**

- Connect the apparatus radio to the cleanest power source possible: a source without motors (i.e. heaters, windshield wipers, etc.), sirens, strobes or flashers.
- Use the same precautions when connecting the intercom power.
- Ensure that the power and grounds connections for the radio and the intercom are clean and light.
- Ensure that the power and grounds wires for the radio and the intercom are no smaller in diameter than 18 AWG.
- Keep all battery connections clean and free from dirt and corrosion.
- Use separate noise filters on radio and/or intercom power as needed.

---

# TROUBLESHOOTING

## TROUBLESHOOTING A HEADSET LOCATION

This procedure will help determine if a problem exists in a particular headset location, and which component in the headset location is faulty.

1. Examine the headset's label to determine if the headset is an Intercom-Only Headset or a Radio-Transmit Headset.
  - If the headset is a FH-10 or a UH-10, it is a Radio-Transmit headset. The speakers should always be active. The mic should always be active for intercom communication and pressing the **Red** PTT button on the ear dome should key the radio for radio transmission.
  - If the headset is a FH-20 or a UH-20, it is an Intercom-Only Headset. The speakers should always be active. The mic should be active for intercom communication only when the **Black** PTT button on the ear dome is pressed. The headset should never cause the radio to key.
  - If the headset is a FH-40 or a UH-40, it is an Intercom-Only Headset. The speakers should always be active. Pressing the **Yellow** PTT on the ear dome will activate the mic for intercom communication. The mic will remain active until the **Yellow** PTT is pressed again.
2. Plug the headset into another good headset location.
  - If the headset fails to perform properly in the new location, the headset is faulty. Contact Firecom for a Return Authorization to return the headset for repair.
3. Unplug the CA Cable from the intercom unit and exchange intercom ports with a known good headset location.
  - If the headset location works properly, check the intercom port for bent or stuck pins which can be straightened.
  - If the headset fails to perform properly, the headset location has a faulty component and you should continue troubleshooting the headset location.
4. Check the HM-10 by exchanging it with a known good one.
  - If the new HM-10 works, check the RJ-12 Modular Jack of the faulty HM-10 for bent or stuck pins. If the pins look good and the HM-10 fails to perform properly, it will need to be replaced.
5. Install new RJ-12 Modular Plugs on **BOTH** ends of the CA Cable (see "Modular Plug Installation" on page 22 for instructions if necessary).
6. Replace the CA Cable.

---

# ADVANCED TROUBLESHOOTING

---

## IMPORTANT

**This section is designed for use by a QUALIFIED TECHNICIAN only!!!**

This section is designed to aid in the troubleshooting process of an intercom system that has been working properly, but has now failed. Make sure you read and understand **THE ENTIRE** procedure **BEFORE** attempting any of the troubleshooting steps in this section. If there are questions regarding this information, contact your local Firecom Dealer for more information **BEFORE** proceeding with the troubleshooting steps.

The System Test on page 17 is also a helpful tool in isolating and determining the actual symptoms of the problem.

### **A) There Is No Sound In The Headset From Either The Intercom Or The Radio**

1. Check the volume control on the headset. Make sure it is not turned all the way down.
2. Check the headset location for faulty connections or components. See “Troubleshooting a Headset Location” (page 25).
4. Measure the voltage between pins 1 & 2 on the Power Cable. There should be at least 11.0 volts DC present, and not more than 15.0 volts DC.
5. Check the wiring to the intercom and any fuses or circuit breakers in the power circuits to the intercom and correct any faults.
6. If there is sufficient power to the intercom, and it doesn’t work, the Intercom Unit is faulty. Contact Firecom for a Return Authorization to return the Intercom Unit for repair.

### **B) There Is Sound In The Headset From The Intercom, But Not From The Radio**

1. Check the radio volume. Make sure it is not turned all the way down.
2. Adjust the Receive Audio Adjustment. See “Intercom Adjustments” (page 15).
3. Verify that receive audio is present by listening to the radio’s speaker.
4. If there is no audio from the radio’s speaker:
  - a. Disconnect the Radio Interface Cable from the back of the intercom unit. If there is audio from the radio’s speaker, the Intercom Unit is faulty. Contact Firecom for a Return Authorization to return the Intercom Unit for repair.
  - b. Disconnect the Radio Interface Cable from the radio. If there is audio from the radios’s speaker, the Radio Interface Cable is faulty.
  - c. If there is still no audio from the radio’s speaker, the radio is faulty.
5. If there is audio from the radio’s speaker, check the connections to pins 6 & 7 on the Radio Interface Port on the back of the intercom unit.
6. Try swapping the intercom unit with a known good one (if one is available). If the problem persists, the problem is in the Radio or the Mobile Radio Interface wiring.
7. If no fault can be found, then the fault must lie in the Intercom Unit. Contact Firecom for a Return Authorization to return the Intercom Unit for repair.

---

## ADVANCED TROUBLESHOOTING

---

### C) There Is Sound In The Headset From The Radio, But Not From The Intercom

1. Check the headset location for faulty connections or components. See “Troubleshooting a Headset Location” (page 25).
2. The Intercom Unit is faulty. Contact Firecom for a Return Authorization to return the Intercom Unit for repair.

### D) There Is Sound In Only One Ear

1. Check to see if the headset is a model UH-10S headset. The UH-10S has one “slotted” ear dome without a speaker in it. This is normal operation for a UH-10S.
2. The headset is faulty. Contact Firecom for a Return Authorization to return the headset for repair.

### E) You Can Hear Others on the Intercom, but they Cannot Hear You

1. If the headset is an Intercom-Only Headset with a **Black** PTT, be sure that the PTT button is fully depressed when trying to talk on the intercom.
2. If the headset is an Intercom-Only Headset with a **Yellow** PTT, press and release the PTT and test again.
3. Check the headset location for faulty connections or components. See “Troubleshooting a Headset Location” (page 25).
4. The headset is faulty. Contact Firecom for a Return Authorization to return the headset for repair.

### F) You Can't Hear Others on the Intercom, but they Can Hear You

1. Check the headset location for faulty connections or components. See “Troubleshooting a Headset Location” (page 25).
2. The Intercom Unit is faulty. Contact Firecom for a Return Authorization to return the Intercom Unit for repair.

### H) The Radio Receive Audio is Weak

1. Check the setting of the radio's volume control. The radio's volume should be set at the normal volume for use with **NO** intercom system present.
2. Adjust the Receive Audio Adjustment. See “Intercom Adjustments” (page 15).
3. Verify proper connection to pins 6 & 7 on the Radio Interface Cable.
4. Try swapping the Intercom Unit with a known good one (if one is available). If the problem persists, the problem is in the radio or the Mobile Radio Interface wiring.
5. If no fault can be found, then the fault must lie in the Intercom Unit. Contact Firecom for a Return Authorization to return the Intercom Unit for repair.

---

## **ADVANCED TROUBLESHOOTING**

---

### **I) The Radio Keys But Has No Transmit Audio (Carrier But No Audio)**

1. Check the affected headset location for faulty connections or components. See “Troubleshooting a Headset Location” (page 25).
2. Check the Transmit Audio Adjustment See “Intercom Adjustments” (page 15).
3. Verify connection of pins 1 & 2 on the Radio Interface Cable and the Radio Interface Port.
4. Try swapping the Intercom Unit with a known good one (if one is available). If the problem persists, the problem is in the Mobile Radio Interface wiring.
5. If no fault can be found, then the fault must lie in the Intercom Unit. Contact Firecom for a Return Authorization to return the Intercom Unit for repair.

### **J) The Radio Doesn't Key**

1. Check the affected headset location for faulty connections or components. See “Troubleshooting a Headset Location” (page 25).
2. Verify connection of pins 3 & 4 on the Radio Interface Cable and the Radio Interface Port.
3. Try swapping the Intercom Unit with a known good one (if one is available). If the problem persists, the problem is in the radio or the Mobile Radio Interface wiring.
4. If no fault can be found, then the fault must lie in the Intercom Unit. Contact Firecom for a Return Authorization to return the Intercom Unit for repair.

### **K) Alternator and/or Strobe Noise is Present in All Intercom Audio**

1. Using a voltmeter, measure the incoming power to the intercom, looking for an AC signal. There should be less than 300 mV AC present on the power lines.
2. Check for proper positioning of the mic in relation to the speaker's mouth. See “Microphone Placement” (page 21). Improper mic positioning will defeat the noise canceling characteristics of the mics.
3. Inspect the headset microphones, making sure that all slots on both sides of the mic are clean and unobstructed. Obstruction of these slots will hamper or defeat the noise canceling characteristics of the mics.
4. Disconnect any exterior headset locations. If the noise stops, inspect that location for water or other contamination. If contamination is present, contact Firecom for a Return Authorization for repair of the unit.

### **L) Alternator and/or Strobe Noise is Present in Transmit Audio Only**

1. Verify that the radio interface pins 1 & 2 are connected properly and that all connections are clean and tight.
2. Check adjustment of the Transmit Audio. See “Intercom Adjustments” (page 15). Too much gain here will cause excessive background noise to be transmitted along with the voice. In the worst case, the voice will be somewhat distorted when transmitting from a quiet place, and will become unintelligible in the presence of background noise.

---

## **ADVANCED TROUBLESHOOTING**

---

### **M) Engine Noise and Sirens are Present in Transmit Audio**

1. Inspect the headset microphones, making sure that all slots on both sides of the mic are clean and unobstructed. Obstruction of these slots will hamper or defeat the noise canceling characteristics of the mics.
2. Check adjustment of the Transmit Audio. See “Intercom Adjustments” (page 15). Too much gain here will cause excessive background noise to be transmitted along with the voice. In the worst case, the voice will be somewhat distorted when transmitting from a quiet place, and will become unintelligible in the presence of background noise.

# WIRING DIAGRAMS

**FIGURE 33**  
HM-10 Wiring

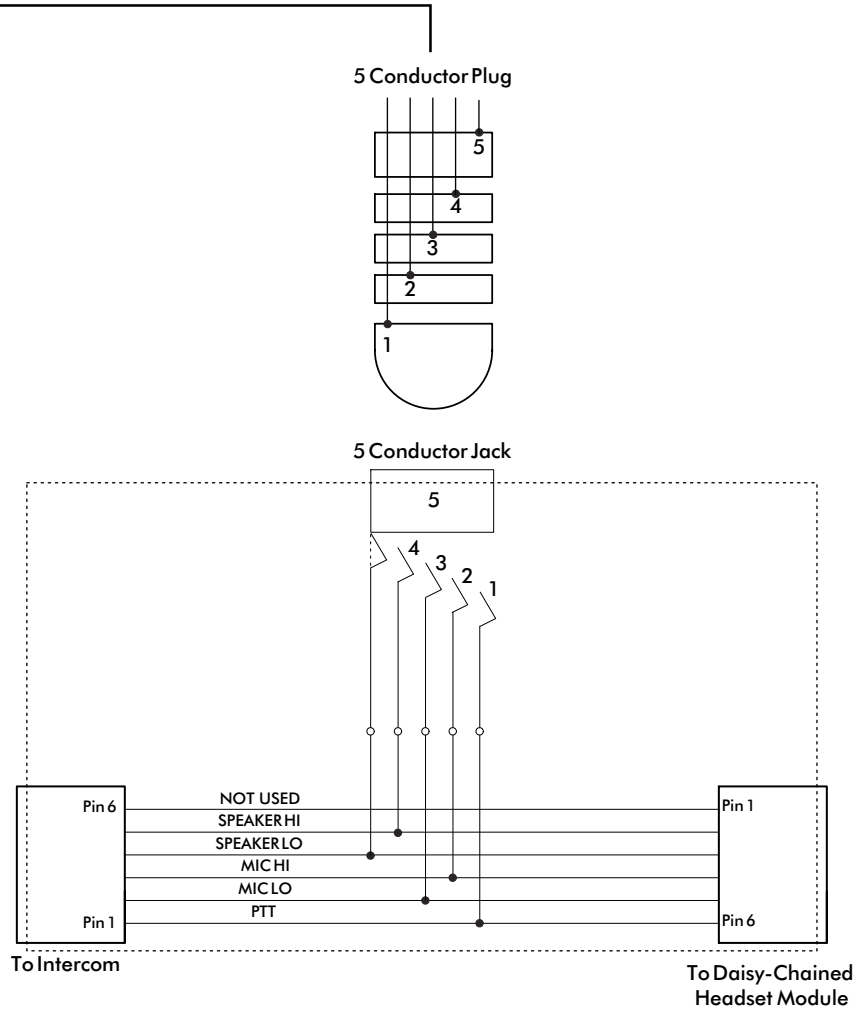

# WIRING DIAGRAMS

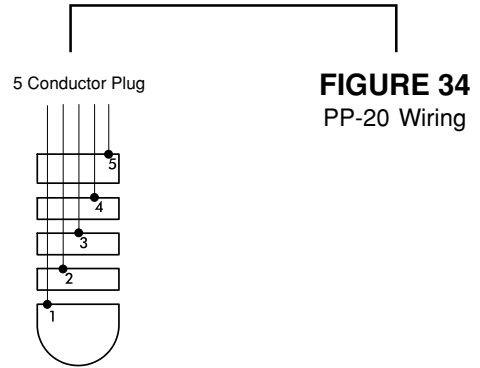

**FIGURE 34**  
PP-20 Wiring

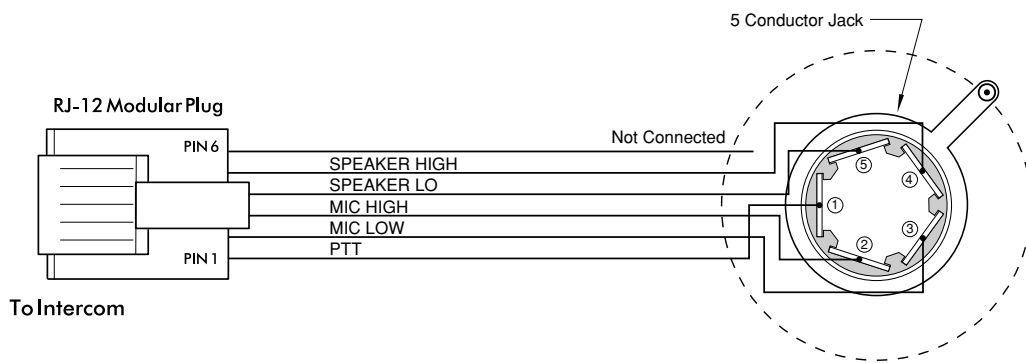

**FIGURE 35**  
CA Cable Wiring

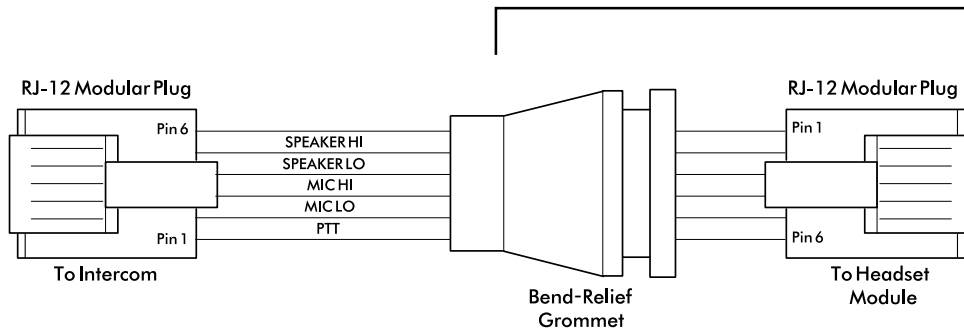

---

## **OPTIONS & ACCESSORIES**

### **HEADSETS**

All Firecom Headsets for the Model 210 Intercom System are equipped with a noise canceling electret condenser microphone on an solid, flexible boom, volume control, adjustable headstrap/headband and liquid foam ear seals. The Firecom headsets provide 24 dB NRR.

#### **FH-10**

Over-the-head style, Radio-Transmit Headset (Red PTT).  
Part Number: 105-0190-00

#### **FH-20:**

Over-the-head style, Intercom-Only Headset (Black PTT).  
Part Number: 105-0191-00.

#### **FH-10S:**

Over-the-head style, single ear, Radio-Transmit Headset (Red PTT).  
Part Number: 105-0194-00

#### **FH-40:**

Over-the-head style, Intercom-Only Headset with alternating push-on, push-off PTT (Yellow PTT). Part Number: 105-0191-10

#### **UH-10:**

Under-the-helmet style, Radio-Transmit Headset (Red PTT).  
Part Number: 105-0192-00

#### **UH-20:**

Under-the-helmet style, Intercom-Only Headset (Black PTT).  
Part Number: 108-0193-00

#### **UH-10S:**

Under-the-helmet style, Radio-Transmit Headset with one empty, slotted ear dome (Red PTT). Part Number: 105-0196-00

#### **UH-40:**

Under-the-helmet style, Intercom-Only Headset with alternating push-on, push-off PTT (Yellow PTT). Part Number: 105-0193-10

### **HEADSET MODULES & EXTENSION CORDS:**

#### **HM-10:**

Interior headset module for use with all headsets listed above.  
Part Number: 107-0407-00

#### **PP-20:**

A water-resistant headset module for use with all headsets listed above.  
Part Number: 107-0413-00

#### **HE-150:**

15-foot coiled headset extension cord. For use with all headsets listed above.  
Part Number: 108-0675-15

#### **HE-150J:**

15-foot coiled extension cord with a male connector at each end, to be used as a jumper between two PP-20 Headset Modules. Part Number: 108-0675-10

---

## **OPTIONS & ACCESSORIES**

### **OTHER ACCESSORIES:**

#### **CLOTH COVERS (DOZEN):**

Replacement cloth covers, sold only by the dozen.

Part Number: 108-0003-00

#### **CRIMPER:**

Crimping tool used for installing the RJ-12 modular plugs onto the CA Cables (instructions included).

Part Number: 108-0023-00

#### **EAR SEAL:**

Replacement liquid foam ear seals, sold by the pair.

Part Number: 108-0012-00

#### **FOOT SWITCH:**

A heavy duty foot switch, for use as a remote PTT.

Part Number: 108-0670-10

#### **HEADSTRAP:**

Cloth headstrap used on the UH-10, UH-10S, UH-20 & UH-40 model headsets.

Part Number: 108-0025-00

#### **HEADSET HANGER HOOKS:**

Rubber-coated, steel headset hanger hook.

Part Number: 108-0676-00

#### **HANDHELD RADIO INTERFACE:**

Works with all Firecom headsets. Contact your local Firecom Dealer for specific information regarding your particular handheld radios.

#### **HS-1:**

System Selector Switch.

Part Number: 108-0677-10

#### **MIC MUFFS (DOZEN):**

Replacement mic muffs with O-rings, sold only by the dozen.

Part Number: 108-0004-00

#### **RJ-12:**

Modular connectors used with the CA Cable to make the interface cables between the intercom and the headset modules. Part Number: 351-0002-00

#### **TRI-COM:**

Triple radio interface for use with the Firecom intercoms.

Part Number: 108-0672-10

---

## SPECIFICATIONS

### **DIMENSIONS:**

L x H x W: 6.15" x 1.28" x 2.75"

Weight: 8.8 ounces

### **POWER REQUIREMENTS:**

+11.5 VDC to +15 VDC

40 MilliAmps (minimum) to 130 MilliAmps  
(maximum - with radio keyed)

### **RECEIVE AUDIO INPUT:**

1000 Ohm nominal impedance

100 Millivolt RMS minimum audible signal

### **TRANSMIT AUDIO OUTPUT:**

6 Volts RMS into 100 Ohm maximum load

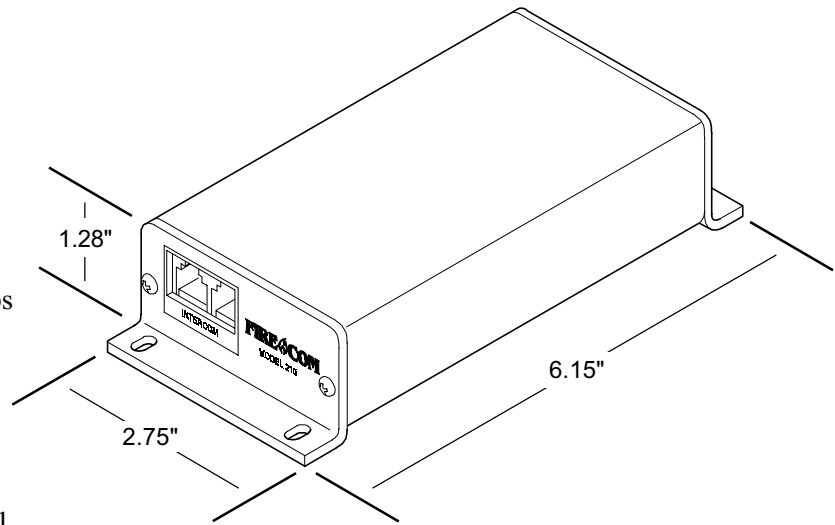

---

## **WARRANTY**

### **TWO-YEAR LIMITED WARRANTY TO ORIGINAL PURCHASER**

Sonetics Corporation warrants to the original purchaser of its products, that they will be free from defects in materials and workmanship, under normal and proper use, for the period of two years from date of purchase. Sonetics Corporation will repair or replace, at its option, any parts showing factory defects during this warranty period, subject to the following provisions. This warranty applies only to a new product which has been sold through authorized channels of distribution. All work under warranty must be performed by Sonetics Corporation. All returned products must be shipped to our address, freight prepaid, accompanied by a dated proof of purchase. The purchaser voids this warranty if he, she or others attempt to repair, service or alter the product in any way. This warranty does not apply in the event of accident, abuse, improper installation, unauthorized repair, tampering, modification, fire, flood, collision, or other damage from external sources, including damage which is caused by user replaceable parts (leaking batteries, etc.). This warranty does not extend to any other equipment or apparatus to which this product may be attached or connected. The foregoing is your sole remedy for failure in service or defects. Sonetics Corporation shall not be liable under this or any implied warranty for incidental or consequential damages, nor for any installation or removal costs or other service fees. This warranty is in lieu of all other warranties, express or implied, including the warranty of merchantability or fitness of use, which are hereby excluded. To the extent that this exclusion is not legally enforceable, the duration of such implied warranties shall be limited to two years from date of purchase. No suit for breach of express or implied warranty may be brought after two years from date of purchase.



**FIRECOM IS A DIVISION OF SONETICS CORPORATION**

7340 SW Durham Road • Portland, Oregon 97224 U.S.A. • 800-527-0555 • 503-684-6647 • Fax: 503-620-2943  
email: [sales@firecom.com](mailto:sales@firecom.com) • [www.firecom.com](http://www.firecom.com)

© 2004, Rev. Sonetics Corporation. All rights reserved. The information in this document is subject to change without notice.  
This document is part number: 600-0210-00. Revision F. Printed in the U.S.A.